

THE INFORMATION CONTAINED IN THIS DRAWING IS THE SOLE PROPERTY OF ROEHRIG ENGINEERING, INC. ANY REPRODUCTION IN PART OR WHOLE WITHOUT THE WRITTEN PERMISSION OF ROEHRIG ENGINEERING, INC. IS PROHIBITED.

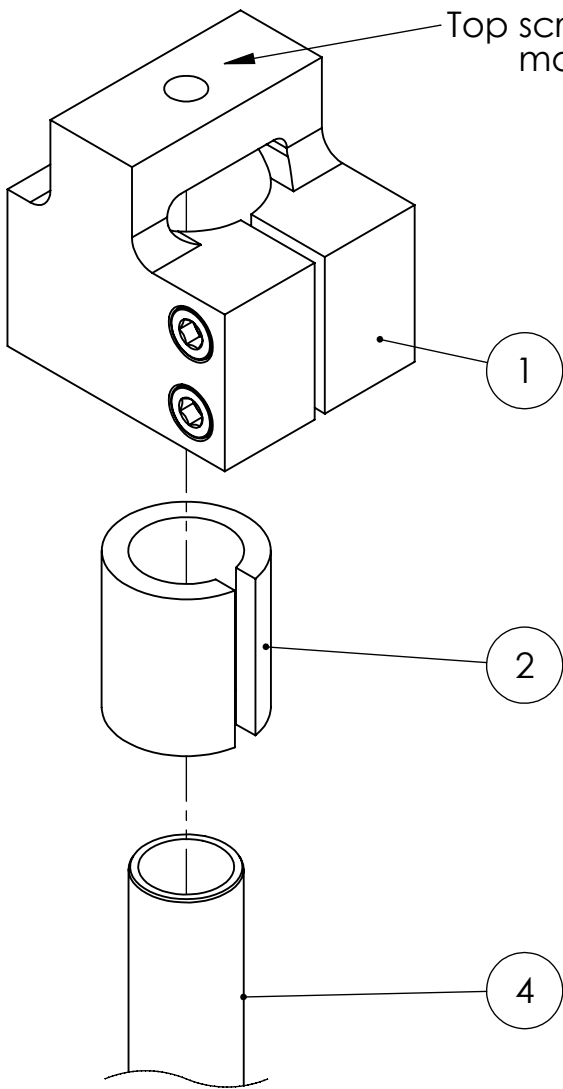

Bicycle Fork Steer Tube

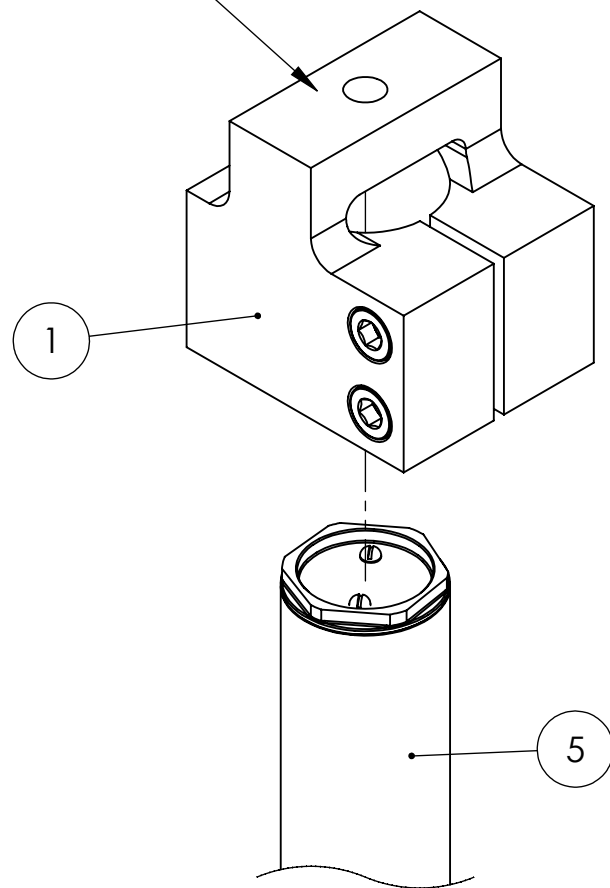

Motorcycle Fork Tube

Part	Description	Qty.	Roehrig Part number
1	Upper Clamp - 56mm ID	1	R-5ABCDE-0061-000
2	Bicycle fork steer tube spacer - 1.50" ID	1	R-5ABCDE-0057-000
3	Bicycle fork steer tube spacer - 1.125" ID (not shown)	1	R-5ABCDE-0058-000
4	Bicycle fork steer tube	1	--
5	Motorcycle fork tube	1	--

UNLESS OTHERWISE SPECIFIED
DIMENSIONS ARE IN INCHES
TOLERANCES ARE:

DECIMALS ANGLES
.X +/- .050 +/-1/4 DEG
.XX +/- .010
.XXX +/- .003

MATERIAL --

FINISH --

DO NOT SCALE DRAWING

CAD GENERATED DRAWING,
DO NOT MANUALLY UPDATE

APPROVALS	DATE
DRAWN MAF	1/14/2008

CHECKED

RESP ENG

MFG ENG

QUAL ENG

ROEHRIG ENGINEERING, INC.

Bicycle - Motorcycle
fork tube clevis
adapters

DWG. NO.	--	REV.	0
----------	----	------	---

SHEET 1 OF 1

