

THE INFORMATION CONTAINED IN THIS DRAWING IS THE SOLE PROPERTY OF ROEHRIG ENGINEERING, INC. ANY REPRODUCTION IN PART OR WHOLE WITHOUT THE WRITTEN PERMISSION OF ROEHRIG ENGINEERING, INC. IS PROHIBITED.

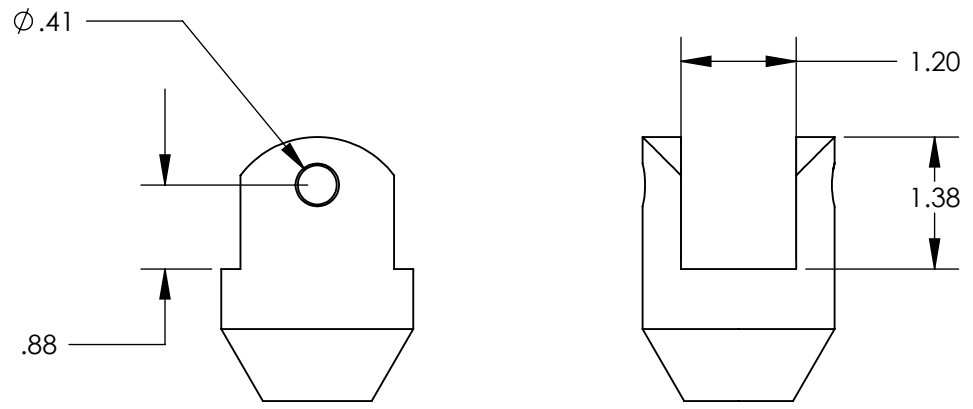
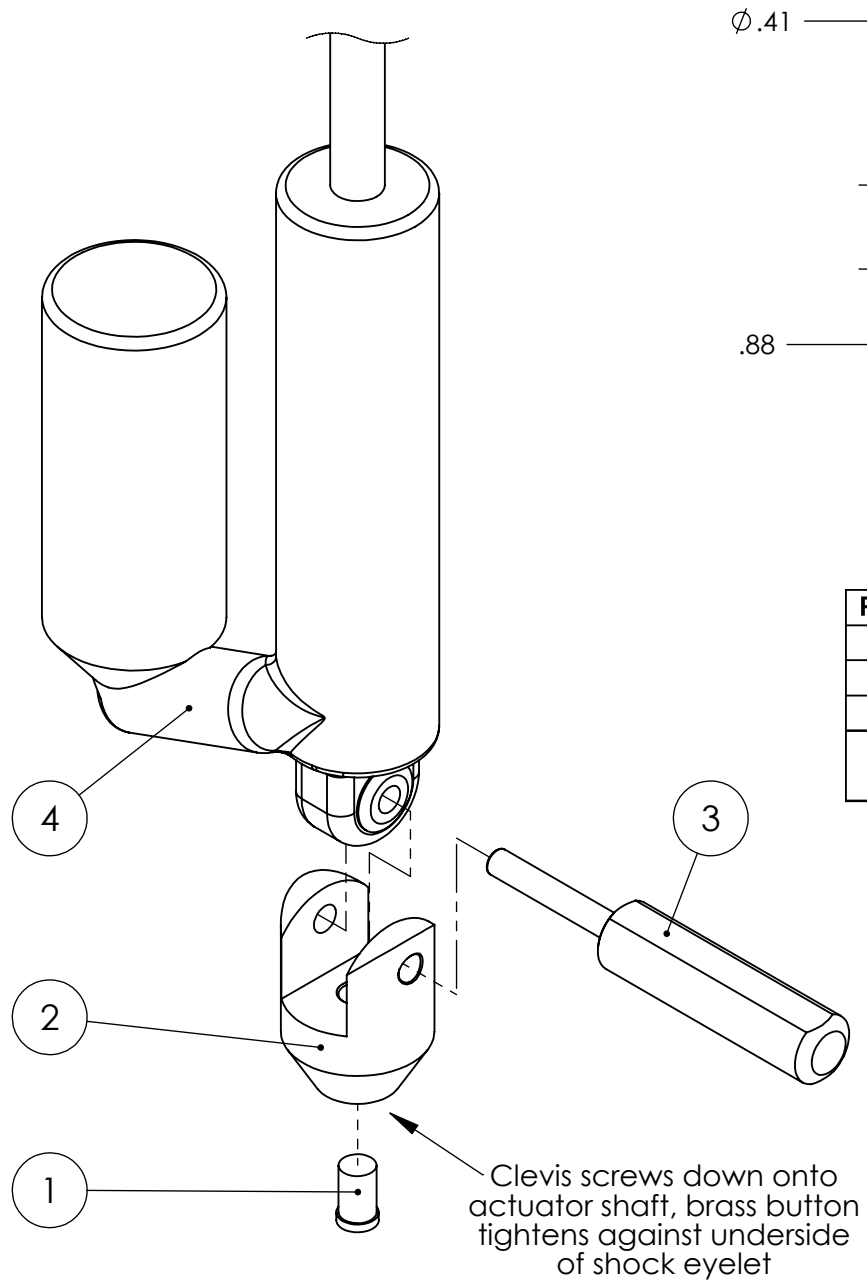

Part	Description	Qty.	Roehrig Part number
1	Brass button	1	R-1ABCDE-0002-000
2	Motocross rear shock clevis	1	R-1E-0014-000
3	Welded eyelet shock absorber	1	--
4	Motocross rear shock absorber with piggyback reservoir	1	--

<p>UNLESS OTHERWISE SPECIFIED DIMENSIONS ARE IN INCHES TOLERANCES ARE:</p> <p>DECIMALS ANGLES</p> <p>.X +/- .050 +/- 1/4 DEG</p> <p>.XX +/- .010</p> <p>.XXX +/- .003</p>	CAD GENERATED DRAWING, DO NOT MANUALLY UPDATE		ROEHRIG ENGINEERING, INC.			
	APPROVALS	DATE			<p>Motocross Shock Clevis Assembly</p>	
	DRAWN	MAF 1/14/2009	DWG. NO. --			
	CHECKED		REV. 0			
MATERIAL	--	SHEET 1 OF 1				
FINISH	--					
DO NOT SCALE DRAWING	QUAL ENG					