

THE INFORMATION CONTAINED IN THIS DRAWING IS THE SOLE PROPERTY OF ROEHRIG ENGINEERING, INC. ANY REPRODUCTION IN PART OR WHOLE WITHOUT THE WRITTEN PERMISSION OF ROEHRIG ENGINEERING, INC. IS PROHIBITED.

Handles thread in from each side. Taper on end of handles fit into eyelet of shock absorber

Clevis screws down onto actuator shaft, brass button clamps against underside of shock eyelet if needed

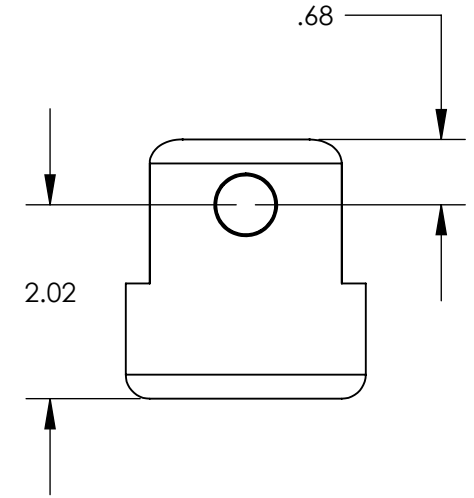
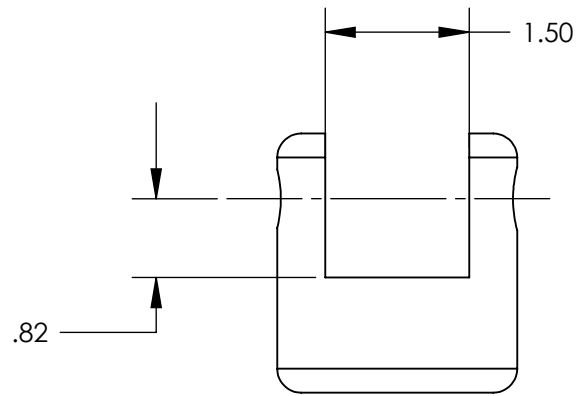
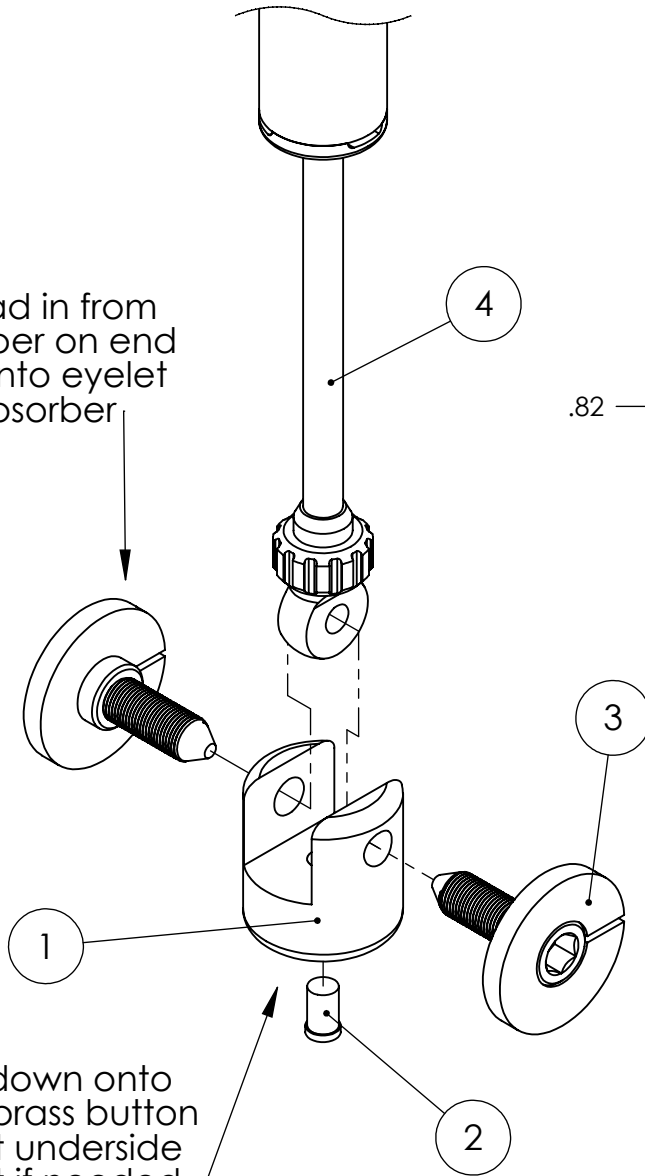

Part	Description	Qty.	Roehrig Part number
1	Universal Clevis	1	R-5ABCDE-0004-000
2	Brass button	1	R-1ABCDE-0002-000
3	Screw in handles	2	--
4	Shock absorber	1	--

UNLESS OTHERWISE SPECIFIED
DIMENSIONS ARE IN INCHES
TOLERANCES ARE:
DECIMALS .X +/- .050
.XX +/- .010
.XXX +/- .003
ANGLES +/- 1/4 DEG

CAD GENERATED DRAWING,
DO NOT MANUALLY UPDATE

ROEHRIG ENGINEERING, INC.

APPROVALS DATE
DRAWN MAF 1/14/2009

Universal Clevis
Assembly

MATERIAL --
FINISH --
DO NOT SCALE DRAWING

RESP ENG
MFG ENG
QUAL ENG

DWG. NO. -- REV. 0

SHEET 1 OF 1